

# Mex Foam Inductors

Designed for use with the Angus Fire range of Medium Expansion MEX Bund Pourers

- Quick response to semi-fixed applications
- Choice of sizes

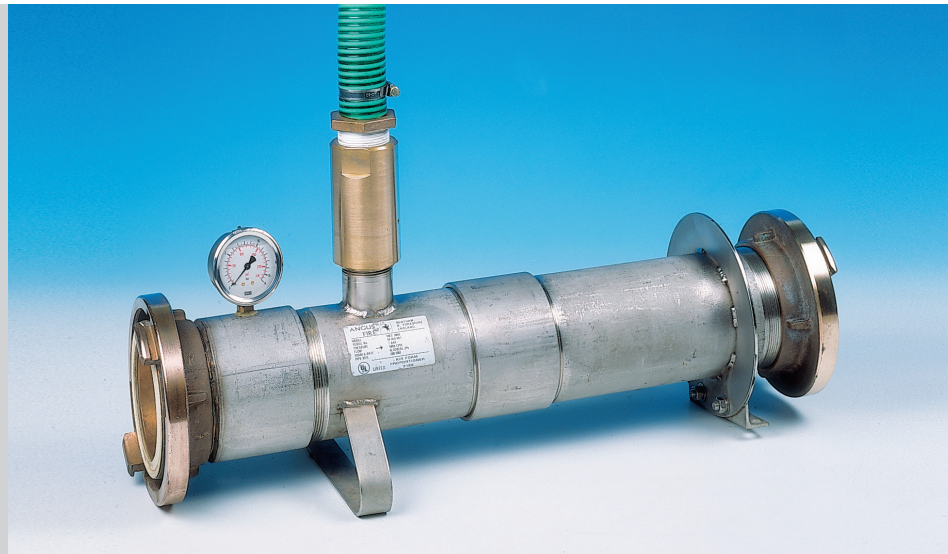

Angus MEX foam inductors are constant flow devices, designed for use with the Angus Fire range of Medium Expansion MEX Bund Pourers for quick response to semi-fixed applications.

The MEX inductor range comprises 3 sizes with flows of 600, 1200 and 1800 litres/minute. These sizes have been specifically matched to the outputs of the Angus MEX Bund Pourers (see data sheets ref 5109, 5101 and 5100 for further details), to facilitate quick and easy set-up in an emergency.

They are intended for operation at an inlet pressure of 7 bar.g. (100 psi) to simplify use with fire vehicles, although calibration for other inlet pressures can be provided if specified when ordering. Up to 50 metres (max.) of Duraline fire hose can be used between each MEX inductor and MEX Bund Pourer, which ensures satisfactory operation, producing generous quantities of fluid yet stable foam. This is ideal for large area fire fighting or hazardous vapour control.

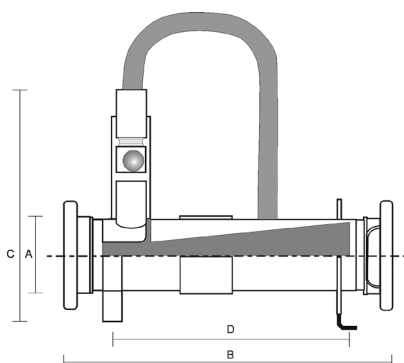

Optimum results are achieved with Angus natural protein based foam concentrates (FP70/FP70 Plus, Petroseal FFFP and Alcoseal AR-FFFP).

For simplicity of use, hydraulic efficiency and speed of deployment, each unit utilises a different line size. All couplings are gunmetal for corrosion resistance and long life, since regular seawater use is anticipated.

Whilst 2½" British Instantaneous couplings (BS 336) are supplied on the MEX 600 inductor, the two larger units are fitted with 75mm and 110mm Storz connections. Alternative BSP male threaded connections are available and other adaptors may be selected from the "Armourite" range.

It is recommended that the MEX Bund Pourers are operated no more than 3 metres vertically above the MEX inductors to avoid back pressure problems occurring, and achieve maximum performance at the pourer.

All units are manufactured from 316 stainless steel for optimum corrosion resistance and reliability. They have a natural finish with polyester internals.

Each MEX inductor is fitted with a non-return valve and 3m pick-up tube, to allow use with 200 litre foam drums. This also avoids the potential risk of water diluting the foam supply, which can be caused by high back pressures occurring due to poor hose configurations, when operating up steep slopes, or mismatching of equipment.

To ensure accurate proportioning, the suction lift should be minimised and the water supply hoses should be no less than the diameter of the inductor. Each MEX inductor is accurately calibrated for the foam type being used. To ensure the correct calibration is achieved, the following parameters must be defined at order stage:

- Foam type to be used.
- Percentage induction rate required (between 1% and 6%)
- Inductor inlet pressure required (if other than 7 bar.g.)

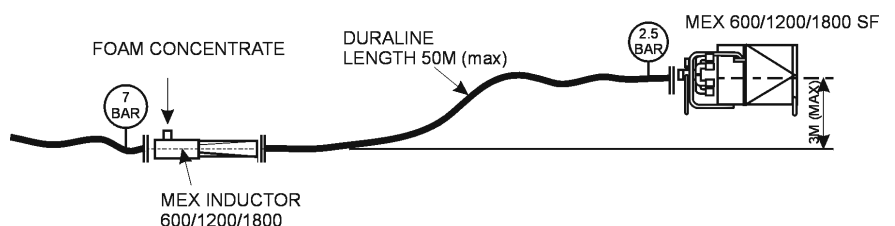

TYPICAL SCHEMATIC LAYOUT

# Mex Foam Inductors

Designed for use with the Angus Fire range of Medium Expansion MEX Bund Pourers

Specification				
MEX INDUCTOR		MEX 600	MEX 1200	MEX 1800
Flow Rate (litres/min)		600	1200	1800
Nominal Pick-up Tube diameter (mm)		25	40	40
MEX Bund Pourer		MEX 600/600SF	MEX 1200/1200SF	MEX 1800/1800SF
Recommended hose and size (mm)		65mm Duraline	75mm Duraline	100mm Duraline
Maximum hose length (metres)		50	50	50
Connections*	MEX inductor inlet	2½" Inst. male GM	75mm Storz GM	110mm Storz GM
	MEX inductor outlet	2½" female GM	75mm Storz GM	110mm Storz GM
	Coupling* req. for MEX Bund Pourer inlet	2½" Inst. male GM	75mm Storz GM	110mm Storz GM

\* Other connections available upon request.

Dimensions (nominal)				
MEX INDUCTOR		MEX 600	MEX 1200	MEX 1800
Line Size (mm)	A	65	75	100
	B	484	476	582
	C	280	330	370
	D	260 centres	300 centres	400 centres
Approximate Weight		5 Kg	12 Kg	20 Kg

## INTERNATIONAL SALES

### Angus Fire Ltd

Angus House, Haddenham Business Park,  
Pegasus Way, Haddenham, Aylesbury, HP17 8LB, UK  
Tel: +44 (0)1844 293600 • Fax: +44 (0)1844 293664

## UK SALES

### Angus Fire Ltd

Station Road, Bentham, Lancaster, LA2 7NA, UK  
Tel: +44 (0)1524 264000 • Fax: +44 (0)1524 264180

Angus Fire operates a continuous programme of product development. The right is therefore reserved to modify any specification without prior notice and Angus Fire should be contacted to ensure that the current issues of all technical data sheets are used.

© Angus Fire  
5143/4 05.16