

Fixed Turbex

FT1 & FT2 for Marine and Industrial Applications

- High expansion foam generators
- Optimum performance



High expansion foam has shown itself to be an exceptionally efficient fire fighting technique for large enclosed areas such as ships' engine rooms, warehouses, packaging plants, ships' holds, mines, chemical stores and incineration plants.

The efficiency of any high expansion foam system depends upon producing well-formed, high quality foam. It must then be delivered rapidly into the risk area, against a possible back pressure that may result from the confines of the application.

The Angus Fixed Turbex Systems employ high expansion foam generators with a cocoon shape designed to optimise performance.

By combining a sophisticated spray nozzle with a uniquely tiered foam making net, the foam bubble structure produced is uniform, slow draining and of a nominal expansion ratio 500:1 (500 parts of air to every one part of foam solution). Air is driven through the generator by a specially developed efficient water driven fan. This forced air technology ensures the foam can be pushed forward overcoming potential back pressures that would stall simpler blower type units.

The FT1-500 P and FT2-500P models must be fed with a premix solution of Expandol foam concentrate and water. Ideally this should be generated using an Angus proportioning device such as a balance pressure proportioner or fixed inductor for maximum accuracy and efficiency.

These premix Fixed Turbex Systems are most effective where multiple units are required to protect large areas with centralised foam proportioning.

The FT1-500S is supplied with an inbuilt induction device. A dedicated Expandol foam tank can be placed adjacent to this Fixed Turbex and all that is needed for operation is a suitable water supply. The selfinducing unit is ideally suited for smaller risk areas.

(for LNG/LPG applications see data sheet 5106)

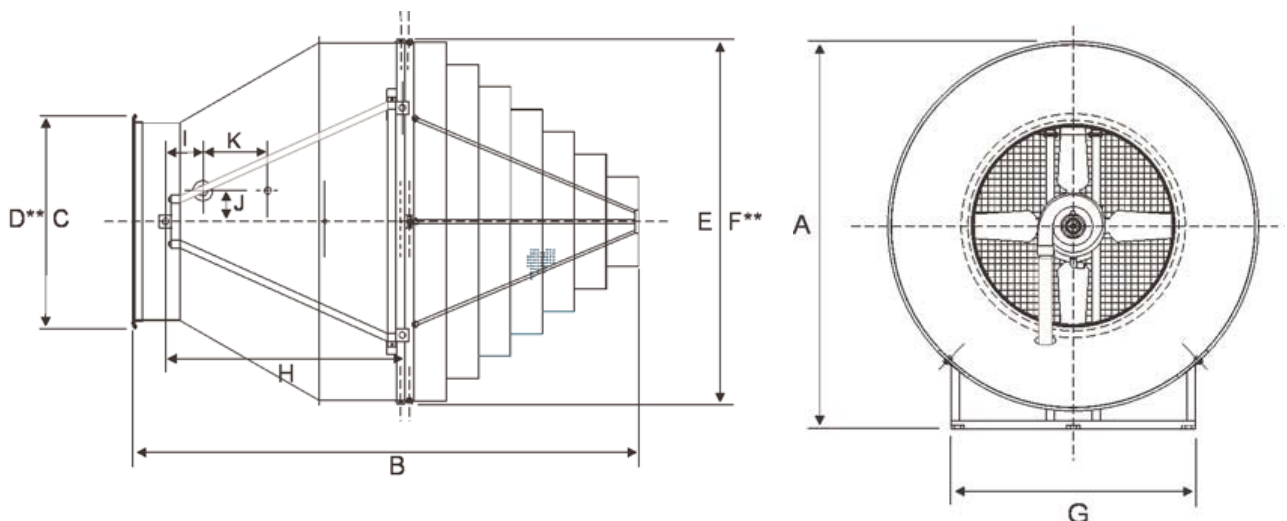
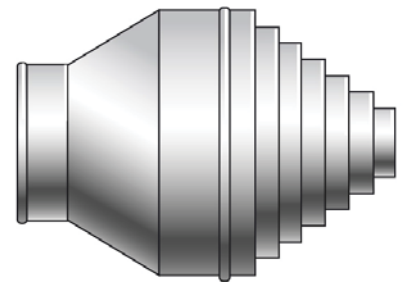

Fixed Turbex

FT1 & FT2 for Marine and Industrial Applications

PERFORMANCE (typical at 18°C)													
		FT1-500P (Premix)				FT1-500S (self-inducing)				FT2-500P (Premix)			
		Flow l/min *	Exp. Foam Output m ³ /min†	Exp. Ratio	K Factor §	Flow l/min *	Exp. Foam Output m ³ /min†	Exp. Ratio	K Factor §	Flow l/min *	Exp. Foam Output m ³ /min†	Exp. Ratio	K Factor §
Inlet Pressure	3bar.g.	138	82	600:1	80	151	83	550:1	87	304	155	510:1	176
Inlet Pressure	5bar.g.	179	100	560:1	80	194	99	510:1	87	393	196	500:1	176
Inlet Pressure	7bar.g.	211	114	540:1	80	230	113	490:1	87	465	214	460:1	176

§ Flow (l/min.) = $K\sqrt{P}$ where P = inlet pressure (bar)

* Conversion factor to **US galls/min** = l/min. x **0.264**

† Conversion factor to **cu ft/min** = m³/min. x **35.64**

SPECIFICATION					
		FT1-500P		FT1-500S	FT2-500P
Dimensions	A (mm)	942		942	1193
	B (mm)	1240		1240	1575
	C (mm)	668		668	668
	D** (mm)	1118		1118	1118
	E (mm)	884		884	1138
	F** (mm)	1118		1118	1372
	G (mm)	460		460	710
	H (mm)	600		600	740
	I (mm)	119.5		119.5	119.5
	J (mm)	85		85	85
	K (mm)	—		124.5	—
Water Inlet Connection				1¼" BSP Taper Male	
Foam Inlet Connection		◆		¼" BSP Taper Male	◆
Materials	Body ‡	Mild steel - yellow thermoplastic powder finish or stainless steel to BS970 316			
	Support Frame ‡	Mild steel - black thermoplastic powder finish or stainless steel to BS970 316			
	Foam Making Net	Stainless steel to BS970 316			
	Turbine	Gunmetal LG2			
	Nozzle	Gunmetal LG2			
	Fan	Light alloy LM25 - black thermoplastic finish LM25-yellow thermoplastic			
	Screws, Nuts, Fasteners			Stainless steel A4	
	Inductor	◆		Gunmetal LG2	◆
Recommended Induction Rate				Expandol at 3%	
Approx. Weight		58kg		60kg	79kg

** Minimum diameter requirements when ducting is used (inlet D, outlet F).

‡ Mild steel recommended for indoor use and stainless steel recommended for outdoor use [these units are not suitable for cryogenic risks (LNG/LPG) see separate Datasheet 5106].

◆ Separate induction device required.

INTERNATIONAL SALES

Angus Fire Ltd

Angus House, Haddenham Business Park,
Pegasus Way, Haddenham, Aylesbury, HP17 8LB, UK
Tel: +44 (0)1844 293600 • Fax: +44 (0)1844 293664

UK SALES

Angus Fire Ltd

Station Road, Bentham, Lancaster, LA2 7NA, UK
Tel: +44 (0)1524 264000 • Fax: +44 (0)1524 264180

Angus Fire operates a continuous programme of product development. The right is therefore reserved to modify any specification without prior notice and Angus Fire should be contacted to ensure that the current issues of all technical data sheets are used.

© Angus Fire
5105/5 02.14