

LNG Turbex Skids

Protection for LNG (Liquefied Natural Gas) spills

- Proven Performance
- Reliable Operation
- Specialist Technology
- Easily Positioned



High expansion foam systems represent the most effective protection for LNG (Liquefied Natural Gas) spills, both for vapour reduction and dispersion as well as for radiant heat reduction and fire control.

Proven Performance

Angus Fire LNG Turbex Skids have been proven to be highly effective on LNG spills and large LNG fires, when used with Expandol foam concentrate. Tests have been conducted during a 2 year programme in association with BP and the Emergency Services Training Institute at Texas A&M University. This is the most realistic and comprehensive LNG test facility, with high specification re-inforced concrete vertical sided containment pits, which include the largest LNG fire test pit in the world (65m²).

Reliable Operation

Few units can be demonstrated to survive and operate in the worst conditions LNG fires can produce. However, LNG Turbex Skids work correctly at temperatures down to -100°C (-148°F) when submerged in cold LNG vapours, rising swiftly up LNG Turbex Skids www.angusfire.co.uk to 1,300°C (2,372°F) after ignition, when engulfed in a flaming LNG fireball.

Specialist Technology

At the heart of the LNG Turbex Skids is the specialised water turbine driven LNG Turbex 500:1 foam generator available in 2 sizes, either FT1 or double the flow FT2 (see FT1 & FT2-500P/LNG data sheet 5106). These generators are made entirely from 316 stainless

steel and Gunmetal. They incorporate an enclosed water turbine and special "pepper-pot" nozzle, robust body, aerofoil fan blades, special bearings, thermal insulation and high temperature lubricants. The LNG Turbex generator is mounted on a rigid 316 stainless steel skid frame that also supports the essential boiler grade 316 stainless steel hood to direct Expandol foam down into the containment pit protecting it against wind effects.

Easily Positioned

LNG Turbex Skids are ideal for retrofitting. They are easily and quickly fork-lifted into position at the LNG containment pit edge, and connected to foam solution pipework to give effective protection. All they require is connection to a pressurised Expandol foam solution supply from a separate Angus Fire water powered foam proportioning skid unit serving the system.

Avoids Escalation

Alternative lower grade materials with thin construction could soften, distort or melt in the severe heat before the unit operates, which could bring the system to a grinding halt and fail to control an LNG fire. Serious escalation and consequential losses could result.

Proven Capability

LNG Turbex Skids have been specifically designed to incorporate specialist features necessary for reliable operation at LNG facilities around the world. They are the units of choice with the world's leaders in LNG technology

and plant operations, discerning LNG facility owners and operators, EPC engineering contractors and FEED consultants. All are now recognising the importance of high specification generators after live LNG fire testing at Texas A&M, using a realistic application rate and achieving control within 60 secs, to protect LNG facilities against fire. Some units not manufactured by Angus Fire have been installed in LNG facilities without fire testing to verify their performance under severe LNG fire conditions. The first few minutes of an incident are critical and it is recommended that all units specified are proven on LNG fires.

Description

Skid mounted water turbine driven LNG Turbex foam generator with aerofoil section fan blades for strength and reliability, special high temperature bearings and lubrication, glass rope lagging around enclosed water turbine, special "pepper pot" nozzle, strengthened multi-tiered net, engineered discharge hood protects against wind without restricting 500:1 expansion of the Expandol foam

Additional drainage slots prevent any residual foam solution entering the LNG pit. The LNG Turbex Skid and Expandol combination has been tested and proven effective on LNG fires of 65m² (700 ft²) area with 150mm (6") depth of LNG, and 45m² (484 ft²) area with 430mm (17") depth LNG with additional watersprays entering the LNG to simulate a severe hazard.

LNG Turbex Skids

Protection for LNG (Liquefied Natural Gas) spills

Specification			
Materials		FT1-500P/LNG	FT2-500P/LNG
Skid frame		316L stainless steel to BS970	316L stainless steel to BS970
Foam generator		316 stainless steel & Gunmetal	316 stainless steel & Gunmetal
Foam hood		316 stainless steel to BS970	316L stainless steel to BS970
Skid Dimensions (nominal)		FT1-500P/LNG	FT2-500P/LNG
Length	(mm) A	2755	3040
Height	(mm) B	1532	1720
Width	(mm) C	1264	1476
Typical nett weight	(kg)	350	500
Typical woodcase packed dimensions	(mm)	2950x1450x1750	3250x1700x2000
Typical woodcase packed weight	(kg)	630	880
Inlet connection		1¼" BSP Male	1¼" BSP Male

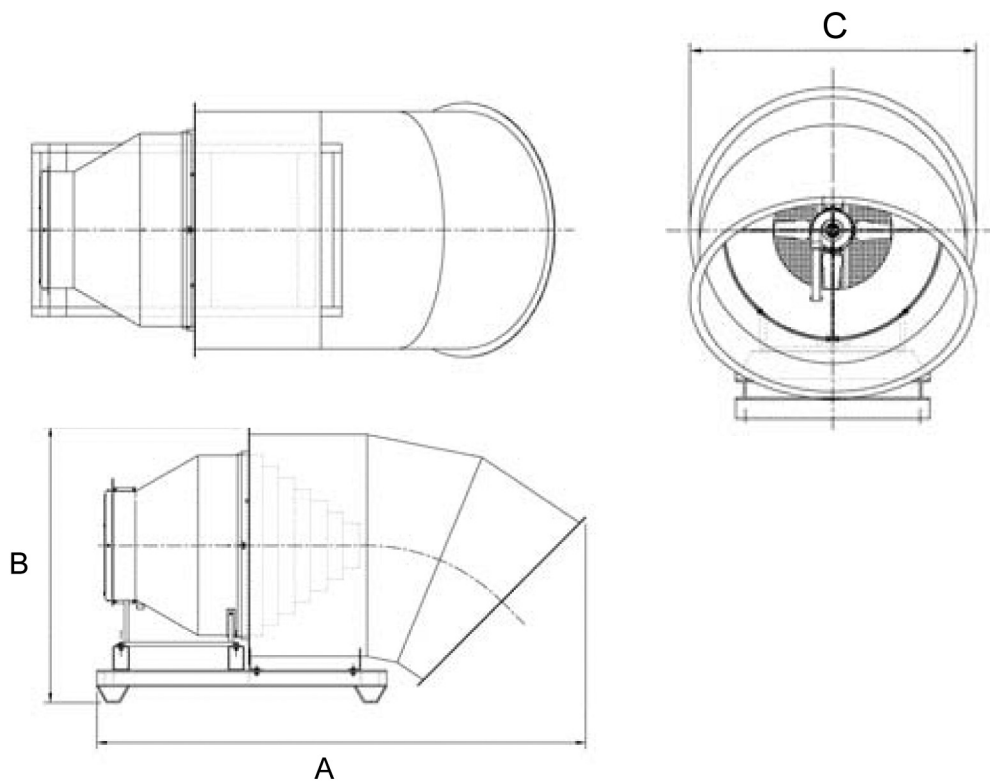

INTERNATIONAL SALES

Angus Fire Ltd
Angus House, Haddenham Business Park,
Pegasus Way, Haddenham, Aylesbury, HP17 8LB, UK
Tel: +44 (0)1844 293600 • Fax: +44 (0)1844 293664

UK SALES

Angus Fire Ltd
Station Road, Bentham, Lancaster, LA2 7NA, UK
Tel: +44 (0)1524 264000 • Fax: +44 (0)1524 264180

Angus Fire operates a continuous programme of product development. The right is therefore reserved to modify any specification without prior notice and Angus Fire should be contacted to ensure that the current issues of all technical data sheets are used.